

Gas Griddle

- EHDG-24 Gas griddle
- EHDG-36 Gas griddle
- EHDG-48 Gas griddle
- EHDG-60 Gas griddle



Model: EHDG-36

STANDARD FEATURES

- Stainless steel front and sides
- Cast iron H-shape burner, each 30,000 BTU/hr
- To be controlled every 12 "
- 3/4 " thickness polished griddle plate
- Standby S/S pilot for easy start
- Adjustable heavy duty legs
- Grease through channel in the front
- Stainless steel oil collector in the bottom
- Stainless steel splash guard at 3 sides
- Durable brass control valve
- Easy access to pilot valve adjustment screws
- Easy gas conversion in field
- 3/4" NPT rear gas connection
- Shipped with gas regulator

INSTALLATION INSTRUCTIONS

1. A gas pressure regulator supplied with the unit must be installed. Natural Gas 4.0" (102 mm) W.C. Propane Gas 10.0" (254 mm) W.C.
2. An adequate ventilation system is required for commercial cooking equipment.
3. These units are manufactured for installation in accordance with National Fuel Gas Code, ANSI-Z223.1/NFPA #54 (latest edition).
4. This appliance is intended for commercial installation only and is not intended for home use.
5. Equipment clearance requirement:

Non-Combustibles	Combustibles
Sides 0"	Sides 4"
Back 0"	Back 4"
6. All the installation must be performed by qualified technicians.
7. For gas conversion, please refer to conversion instructions in the Instruction Manual Book.

Gas Griddle

Plan View

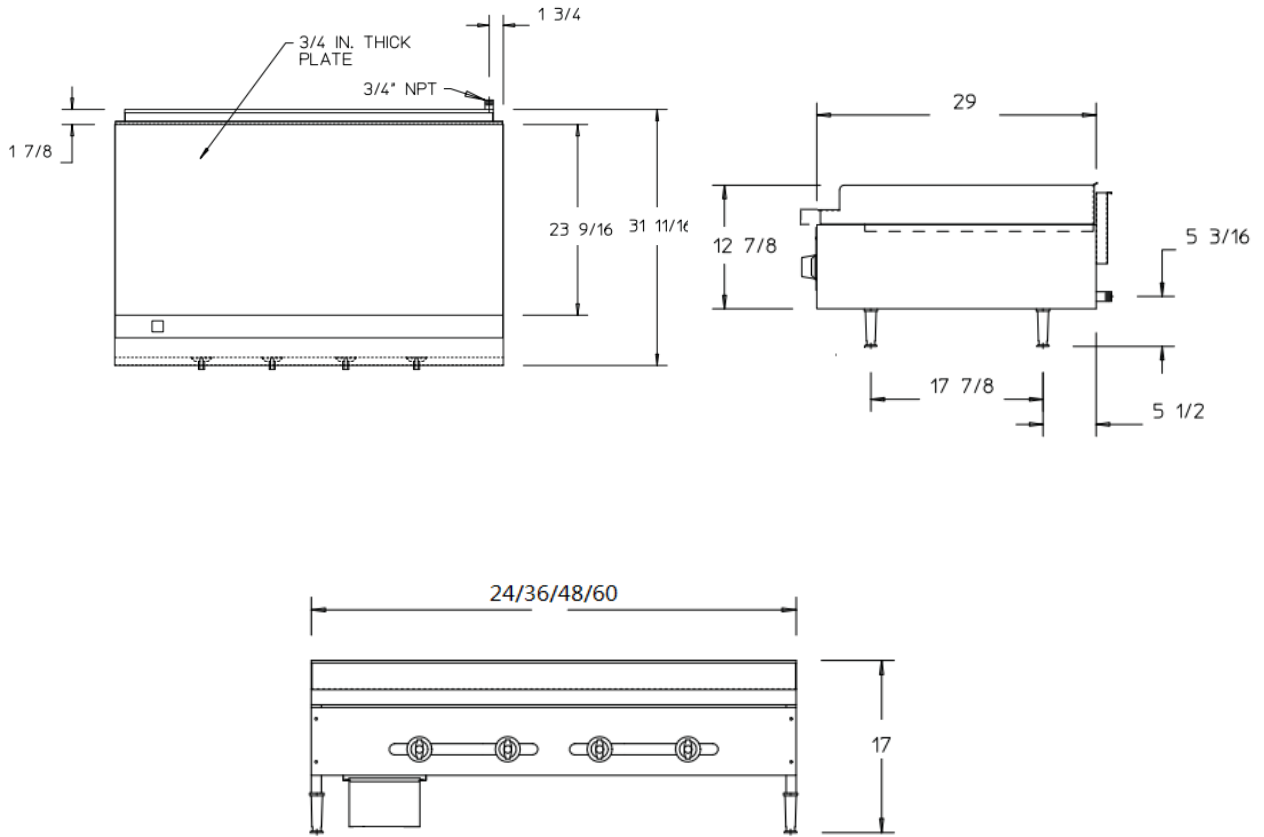

Model	BTU/HR	Cooking dimension	Burner Qty	Packing Size(IN)	N/W (LB)	G/W (LB)
EHDG-24	60,000BTU	24x24	2	28x38x22	203	254
EHDG-36	90,000BTU	36x24	3	42x38x22	285	340
EHDG-48	120,000BTU	48x24	4	53x38x23	373	450
EHDG-60	150,000BTU	60x24	5	65x38x23	510	560