

REFRIGERATOR MANUFACTURER
Turbo air
 more durable, efficient, beautiful

4184 E. Conant St.
 Long Beach, CA 90808
 Tel. 310-900-1000
 Fax. 310-900-1077
www.turboairinc.com

Project :	
Model # :	
Item # :	Qty :
Available W/H :	
Approval :	

Swing Door Merchandisers

Glass Door Merchandisers
 Super Deluxe Series

Model : TGM-20SD

FEATURES & BENEFITS

■ **Maintenance-free, Self-Cleaning Condenser (patented)** Only at Turbo Air

The accumulation of dust in the condenser causes the failure or breakdown of refrigerators. Refrigerators run normally until they reach a certain level of accumulation. At some point, when they are over the limit, their performance drops quickly resulting in damage to, or disposal of the stored products in refrigerators. The self-cleaning condenser device keeps the condenser clean and prevents system failure by automatically brushing daily.

■ **Energy conserving fan control**

Utilizing algorithmic air circulation for optimal temperature levels, our innovative fan control system conserves energy by at least 15% and increases compressor life by up to 30%.

■ **Digital temperature control & monitor system**

- Keep food products safe by maintaining constant temperatures.
- Alarms that sound when doors are not sealed shut; protect against food spoilage that originate from cold air leaks.
- Early Warning Alarm program detect issues before malfunction occurs.
- Digital display allows for easy monitoring.
- Programs interpret the condition of refrigeration systems by self-diagnosis.
- Rapid cool-down function (Turbo cooling).
- Automatic evaporator fan motor delays.

■ **Double pane glass doors with Low-E glass**

Energy saving double pane glass doors are equipped with Low-emissivity glass, which reduce outer heat gain and decrease energy consumption. It enhances energy efficiency and minimizes condensation. Lightweight door construction also reduce door maintenance and bushing wear, which in turn facilitates smoother door openings.

■ **Shadow free advertising panel**

Turbo Air is the pioneer in the refrigerator industry on applying special LED Light Guided Panels (LGP). LGP increases panel visibility and eliminates shadows, thus enhances any store atmosphere with eye-catching effects. LED lighting offers 5 times longer lasting life than fluorescents and conserves energy as well.

■ **Efficient refrigeration system**

Turbo Air's glass door refrigerators are designed with oversized and balanced (CFC Free R-134A) refrigeration systems. These include efficient evaporators and condensers for faster cooling and greater efficiency.

■ **High-density polyurethane insulation**

The entire cabinet structure is foamed-in-place using high density, CFC free polyurethane insulation.

■ **LED lighting interior**



TGM-20SDW



TGM-20SDB

Refrigerator holds 33°F ~ 38°F for the best in food preservation

Patented Self-Cleaning Condenser



This product is equipped with a fine mesh filter to the front of the condenser to catch dust, and a rotating brush that moves up and down daily to remove excess buildup outward and away.



Model	Swing Door	CU./FT.	#of Shelves	HP	AMPS	Crated Weight (lbs.)	L x D* x H† (inches)
TGM-20SD	1	16.01	4	1/4	5.5	292	27 x 263/8 x 77

Model : TGM-20SD

ELECTRICAL DATA	
Voltage	115/60/1
Plug Type	 NEMA 5-15P
Full Load Amperes	5.5
Compressor HP	1/4
Cord Length (ft.)	9.8
Refrigerant	R-134A
DIMENSIONAL DATA	
# of Doors	1
Net Capacity (cu. ft.)	16.01
Ext. Length Overall (in.)	27 (685mm)
Ext. Depth Overall (in.)*	26 ³ / ₈ (670mm)
Ext. Height Overall (in.)†	77 (1955mm)
Int. Length Overall (in.)	23 (585mm)
Int. Depth Overall (in.)	21 ⁷ / ₈ (555mm)
Int. Height Overall (in.)	60 ¹ / ₄ (1530mm)
Net Weight (lbs.)	269
Gross Weight (lbs.)	292
# of Shelves	4
Shelf Size (L x D) (in.)	21 ¹ / ₂ x 17 ¹ / ₂

Design and specifications subject to change without notice.
Actual shipping weight may differ due to extra packing materials for product protection.
* Depth does not include 2-1/4" (57mm) for door handle.
† Height does not include 2-1/2" (63mm) for leg height.

■ **WARRANTY : 3 Year Parts and Labor Warranty
Additional 2 Year Warranty on Compressor**

- **Door locking system standard**
- **4" dia. casters available (optional)**
- **Two color options available (standard):** white cabinet (W), black cabinet (B)

■ **OPTIONAL ACCESSORIES :**

- 4" caster, 1/2" diameter & 13 TPI: G8F6500101 (non-brake), G8F6500201 (w/ brake)
- Additional PE coated wire shelf: P0178H0100

PLAN VIEW

(unit : inch)

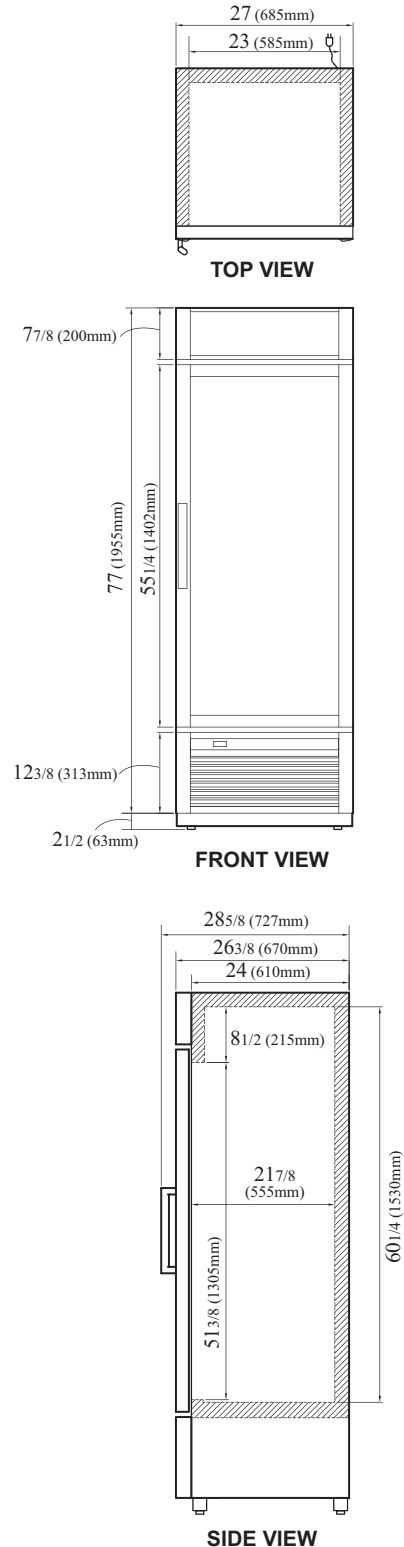

Ver.201701



- Turbo Air : 800-627-0032
- GK : 800-500-3519
- Warranty : 800-381-7770
- AC : 888-900-1002