



---

**BD**

---

## Storage Freezer

# KEY ASPECTS

## SPECIAL FEATURES:

- Efficient cold wall refrigeration system
- Environmentally friendly hydrocarbon refrigerant
- One basket

## OPTIONS:

- Graphics
- Extra baskets

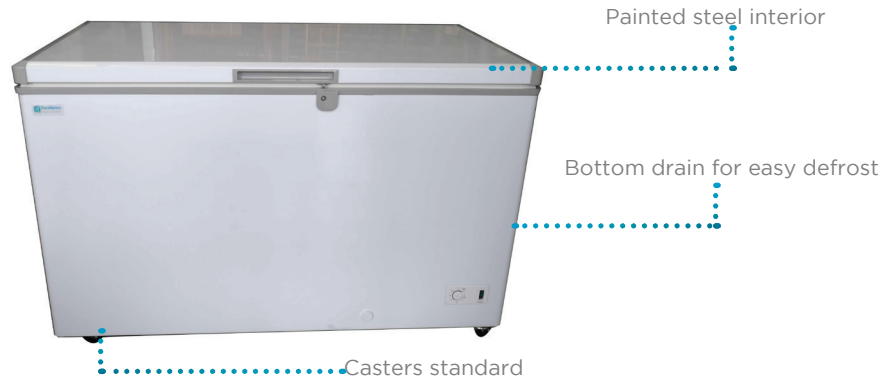

Complies with 2017 DOE standards for commercial freezer with solid door

## TECHNICAL SUMMARY

MODEL	SIZE				ELECTRICAL	REFRIGERATION			OTHER	
	Dimensions (inches)* Width x Depth x Height	Cubic Feet	Net Weight (lbs.)	Shipping Weight (lbs.)**	Voltage/Hz/Phase	Running Amps	Compressor HP	Refrigerant	Temperature	Container Quantity
BD-11	43 1/2 x 29 1/4 x 33 3/8	10.7	132	148	115/60/1	1.9	1/8	R-600a	-14°F to +6°F	90
BD-13	51 3/4 x 29 1/4 x 33 3/8	13.2	148	165	115/60/1	1.9	1/8	R-600a	-14°F to +6°F	75
BD-16	59 1/2 x 29 1/4 x 33 3/8	15.8	176	194	115/60/1	1.9	1/5	R-290	-14°F to +6°F	66
BD-19	70 7/8 x 29 1/4 x 33 3/8	19.1	192	216	115/60/1	1.9	1/5	R-290	-14°F to +6°F	56

\*Dimensions are all nominal lengths

\*\*Does not include weight of pallets when needed



500 S. Falkenburg Road  
Suite 200 | Tampa, FL 33619  
800.441.4014 | 813.870.0340  
www.excellenceindustries.com  
ver. 10.20

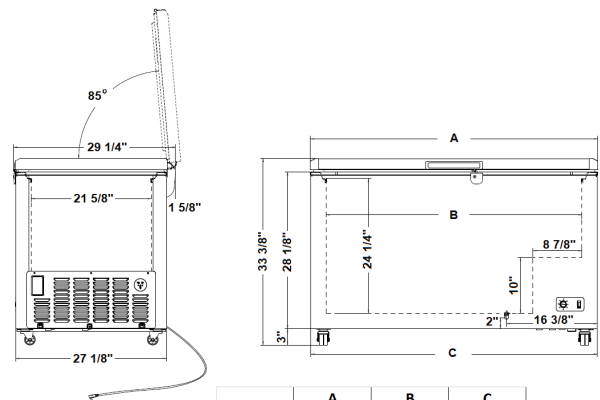

	A	B	C
BD-10	43 1/2"	37 3/4"	43 3/8"
BD-13	51 3/4"	46"	51 5/8"
BD-19	59 1/2"	53 3/4"	59 1/4"
BD-19	70 7/8"	65 1/8"	70 3/4"